

# Zip Hydroboil<sup>®</sup>

Instant boiling water



- 11062 Hydroboil Electronic 15 Litre White
- 11061 Hydroboil Electronic 15 Litre S/S
- 12062 Hydroboil Electronic 25 Litre White
- 12061 Hydroboil Electronic 25 Litre S/S
- 04062 Hydroboil Electronic 40 Litre White
- 04061 Hydroboil Electronic 40 Litre S/S

**FILTERIFIC**

Tel 9352 5499

[www.filterific.com.au](http://www.filterific.com.au)

*Fit For Every Body*



**Zip<sup>®</sup>**

*Instant Boiling Water*

## Contents

Read These Warnings First .....	3
Installation Requirements .....	3
Installation Procedures .....	4
Step 1 – Positioning .....	4
Step 2 – Fastening .....	4
Step 3 – Connecting .....	5
a) Plumbing .....	5
b) Venting .....	5
c) Electrical .....	6
Step 4 – Assembling .....	6
Step 5 – Commissioning ...	6
Problem Solving .....	7
Operating Procedures .....	7
Wiring Diagram .....	8
Mounting Template .....	9
Main PCB Settings .....	10
Connecting John Guest Fitting .....	10
Spare Parts .....	11
Warranty .....	12

## Read These Warnings First



Please read all installation requirements, installation procedures and precautions before installing any Hydroboil instant boiling water heater.

Never attempt to install any Hydroboil instant boiling water heater without reading all of the applicable instructions.

In some hard water areas where mineral scale accumulation in the boiling chamber of the Hydroboil may become a problem, consideration should be given to the maintenance required. A suitable form of water treatment may be necessary.

The cold water supply to this appliance must be potable and fall within your local water authority guidelines.

All plumbing connections must be made in accordance with local authority requirements.

The Hydroboil instant boiling water heater is not intended for use by young children or infirm people without supervision.

Young children should be prevented from having access to ensure that they are not able to use or play with the heater.

If the installation site is located more than 1000 metres above sea level, the installer should contact a authorized agent to obtain alternate PCB settings.

If the power supply cable is damaged it must be replaced by a Authorized Service Provider or a qualified electrician.

Do not remove the cover of the heater under any circumstances without first isolating the heater from the power supply.

Do not use strong, corrosive or abrasive cleaners to clean the case of the heater.

Frost protection: If this heater is located where ambient air temperature could fall below 5°C when the heater is not in use, do not turn off the appliance electrically. This safeguard does not offer the same protection to the connecting pipework and fittings.

The ambient temperatures this unit should operate with is 5 °C - 50°C

This heater is intended only for indoor use and should never be installed outdoors or be exposed to the elements of nature.

This unit must not be positioned in an area that may be cleaned by a water jet. This unit must not be cleaned by a water jet.

## Installation Requirements

Before installing, ensure that the following are available:

- a) Sufficient space to position the heater so there is at least 150 mm clearance above the heater for service access, 65 mm to its left and 20 mm to its right – the tap outlet usually should be positioned at least 200 mm above a draining board or drip tray.
- b) For units with 2.4 Kw element (15 ltr) standard 10 amp 220-240 volt power cable positioned as shown on the paper mounting template for connection from the rear of the heater to the terminal block within the heater, OR a standard 10 amp 220-240 volt power outlet on the wall within 1500 mm of the heater. For units with 3.6 Kw element (25 ltr) or multi element units (40 L) an isolating switch in the fixed wiring and attached to a secure surface is required.

## Installation Requirements continued

This switch must provide all-pole disconnection and a contact separation of at least 3 mm installed in accordance with wiring rules.

- c) Cold water supply with a minimum working pressure of 100 kPa and a maximum working pressure of 700 kPa connected via an isolation valve.
- d) Outlet drainage to a sink draining board or to a drip tray.
- e) Access to drainage from a vent situated at the base of the heater.
- f) In all installation instances the walls of the heater must be vertical and the base horizontal, there can be no exceptions to this rule.

**Note:** If the water pressure is likely to exceed 700 kPa, a 350 kPa pressure reducing valve must be installed in the cold water supply line.

## Installation Procedures

### Before you begin

Locate the paper mounting-hole template packed with the heater.

Read the installation and operating instructions completely.

Decide whether to install with concealed or exposed plumbing and / or electrical connections. Concealed connections are preferred for a superior appearance.

If the heater is used for filling cups, then insert the flow restrictor into the outlet pipe before securing tap assembly.

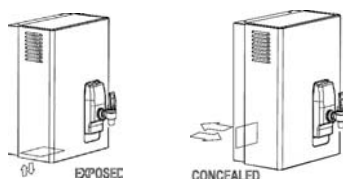
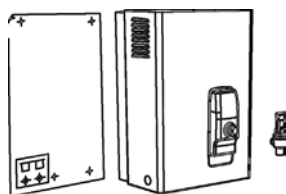

### Step 1 - Positioning

Position the heater so the tap will drain onto the draining board or drip tray.

Position the base of the tap to be not less than 200 mm above the draining board. (height should be increased only if it is essential to accommodate larger vessels.)

Minimum clearances for service are 150 mm top, 65 mm left and 20 mm right.

Mark corner position on wall so to position mounting-hole template.

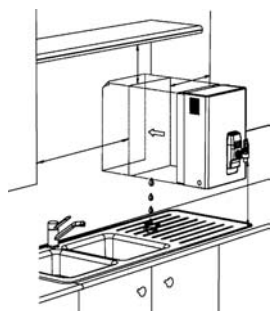

### Step 2 - Fastening

Position mounting-hole template on the wall and drill mounting holes where shown.

Drill holes for water inlet, vent outlet and wiring if it is intended to install the heater with concealed electrical and plumbing connections.

Remove cover fastening screws and lift cover away from chassis.

Install plumbing and wiring, and prepare pipe ends for connection as shown in step 3.

Screw heater chassis to wall using screws or bolts suited to the wall surface. Screws/bolts must be able to support the following weights when filled.

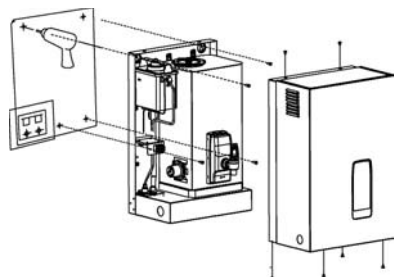

15 litre models	34.5 kgs
25 litre models	47 kgs
40 litre models	71 kgs

### Front View

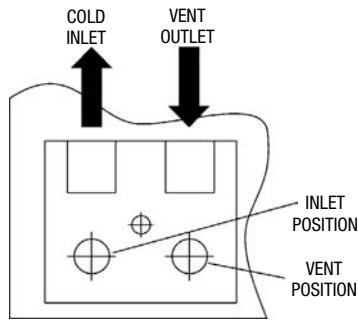

### Side View

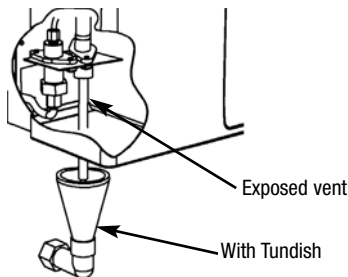
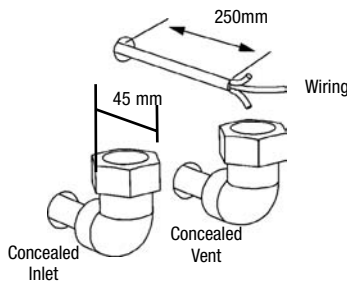
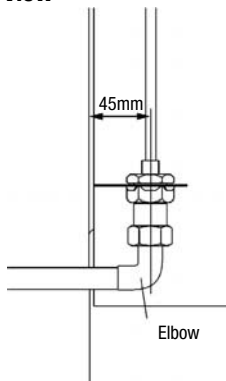

## Step 3 – Connecting

### a) Plumbing

For exposed plumbing connection, connect the cold water inlet pipe from the base of the heater directly to the 15 mm compression fittings.

For concealed plumbing connections, connect the cold water pipe through the rear of the chassis using a 15 mm capillary elbow (# 63 Swivel Elbows).

Cold water pipes must be flushed before connection to the inlet. Any clogging due to sediment or fines will adversely affect the operation of the heater.

It is recommended that the heater be installed with a isolating valve which allows it to be isolated from the mains supply for servicing.

### Water pressure requirements:

Minimum - 100 kPa, Maximum - 700 kPa.

Warning: If pressure is likely to exceed 700 kPa, a pressure limiting valve must be installed in the cold water supply line. We recommend a valve rated at 350 kPa for this application.

### b) Venting

A vent at the base of the heater must be plumbed to a safe visible location as, under certain conditions, it may discharge cold or boiling water and/or steam.

For exposed vent plumbing, connect vent outlet from the base of heater to a 15 mm OD pipe which has a continuous fall, is no more than 3 metres long, has no more than 3 right angle bends, and discharges to a waste water drain.

For concealed vent plumbing, connect plumbing to the vent outlet from the heater rear using a capillary elbow protruding 45 mm from the wall.

Alternatively attach a tundish to the wall as shown and plumb away to waste.

Wall mounted tundish - p/n 99017

Sink mounted tundish- p/n 99018

## Installation Procedures continued

### c) Electrical

For concealed electrical connection, connect a power cable from the rear of the heater to the terminal block within the heater as shown.

**Do not turn the power ON** until the heater is filled with water.

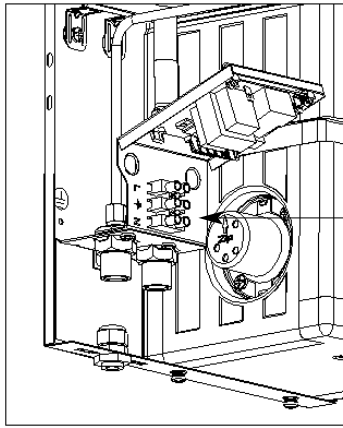

Single element  
PCB and connections

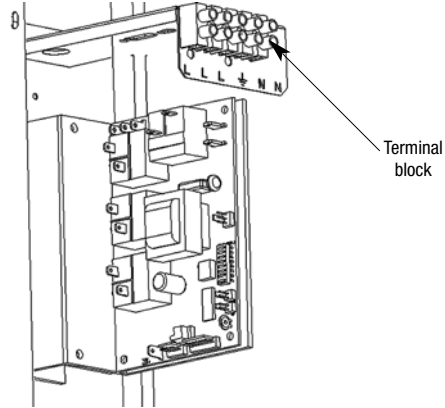

Multiple element  
PCB and connections

Size	Kw	Amps
15 Ltr	2.4 kW	10 A
25 Ltr	3.6 kW	15 A
40 Ltr	6.0 kW	25 A

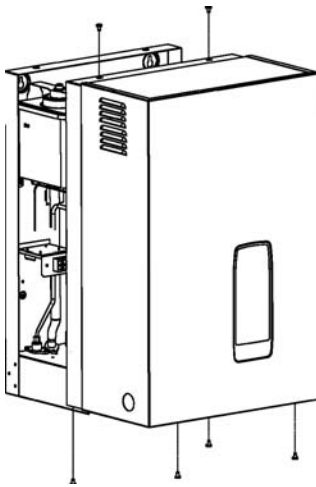

#### Step 4 - Assembling

Place the heater case back onto the chassis and secure the two top and four bottom fixing screws.

Screw the tap assembly clockwise onto the tap outlet tube using PTFE tape.

Screw the tap clockwise until the tap assembly touches the fascia without pressure.

Continue to turn the tap a further one full turn until the tap lever is upright.

#### Step 5 - Commissioning

Check previous steps. Turn water supply ON, check connections for leaks.

Turn tap handle to the "lock down" side and leave open until water starts flowing from the outlet. Return the handle to the closed position to stop water flow and turn the handle 180° to the "cup fill" position.

See page 8 for LED Display information.

Turn power on. After a short time, boiling water will be available and will be maintained close to boiling point thereafter. Initial heating periods are:

Inlet water temperature	15°C	10°C
15 Litre models	40 minutes	43 minutes
25 Litre models	47 minutes	50 minutes
40 Litre models	60 minutes	64 minutes



## Problem Solving

Symptom	Possible Cause	Solution
Fails to dispense water.	Water isolating valve turned off. Blocked filter, blocked meter tube, blocked strainer, jammed ball valve assembly, airlock in transfer tube.	Check water supply valve. Contact a Zip authorised agent.
Water not boiling.	No power.  Faulty thermostat, faulty element, faulty cutout, faulty contactor.	Check power supply.  Contact a Zip authorised agent.
Runs out of boiling water and fails to refill. Outlet tap drips. Overflow from vent. Excessive steam from vent. Power "on" but no heat. Overload repeatedly tripping with excessive steam. Overload repeatedly tripping without excessive steam.	Internal adjustment.	Contact a Zip authorised agent.

## Operating procedures



### Tap Operation

Hydroboil is fitted with a two-way safety tap.

The tap assembly has two positions, one is the "cup fill" quick return mode. This operation is achieved by having the handle with the curved cam at the base of the tap handle facing you. When the handle is released this mode allows instant water cutoff.

The second mode is "pot fill", to use this position rotate the handle 180° from the "cup fill" side so a flat face cam is showing at the handle base. This operation allows a vessel to be filled without holding your hand where it may be affected by steam.

## Operating procedures continued

### Reading the Display Screen

#### Power On

When the text 'Power On' is illuminated this indicates that the power is connected and turned on and that the heater is operating normally.

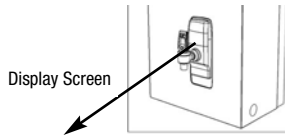

#### Boiling Water

When the text 'Boiling Water' is illuminated this indicates that the contents of the boiling chamber has been brought to boiling point and is being maintained (normally within 1°C of boiling point). During the initial heat-up the contents of the boiling chamber may be below boiling point for a period, and during that period the text 'Boiling Water' may not be illuminated.

#### Filter Active

If your Zip Hydroboil is specified with a filter the 'Filter Active' text will normally be illuminated. This indicates that the filter is within its specified lifespan.

#### Change Filter

If your Zip Hydroboil is specified with a filter the 'Change Filter' light will illuminate when the filter is due to replacement. The local toll free number (directly above) will also illuminate showing the Zip service number 1800 638 633.

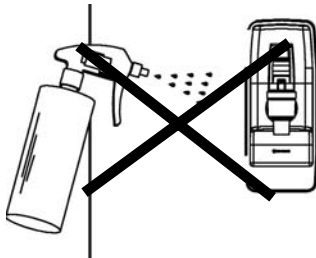

#### Cleaning Case

Do not use strong, corrosive, spray or abrasive cleaners. Clean the case with a soft cloth or brush and mild soap and water.

## Wiring Diagrams

15 Lt & 25Lt HB SINGLE ELEMENT  
WITH PCB CONTROLLER  
WIRING DIAGRAM

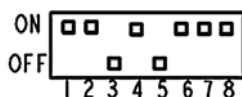
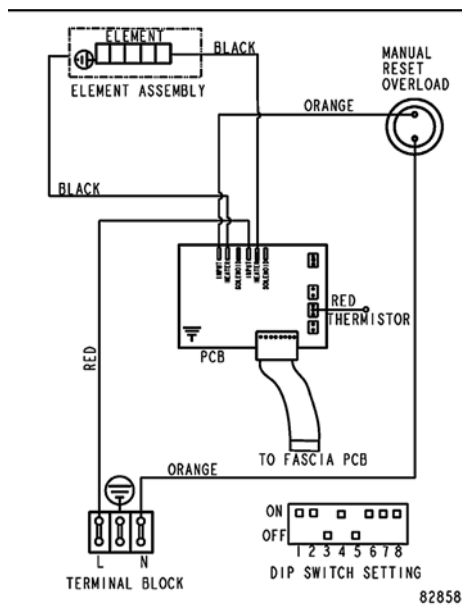

Factory dip switch settings  
single element.

40 Lt HB MULTI - ELEMENT  
WITH PCB CONTROLLER  
WIRING DIAGRAM

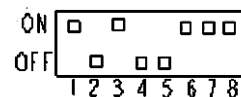
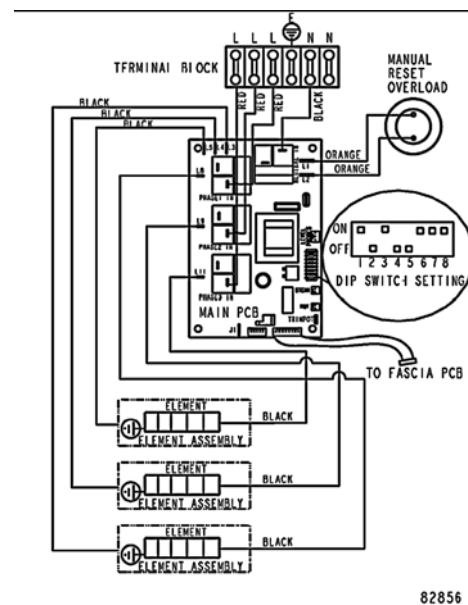

Factory dip switch settings  
multi element.

# Mounting Template

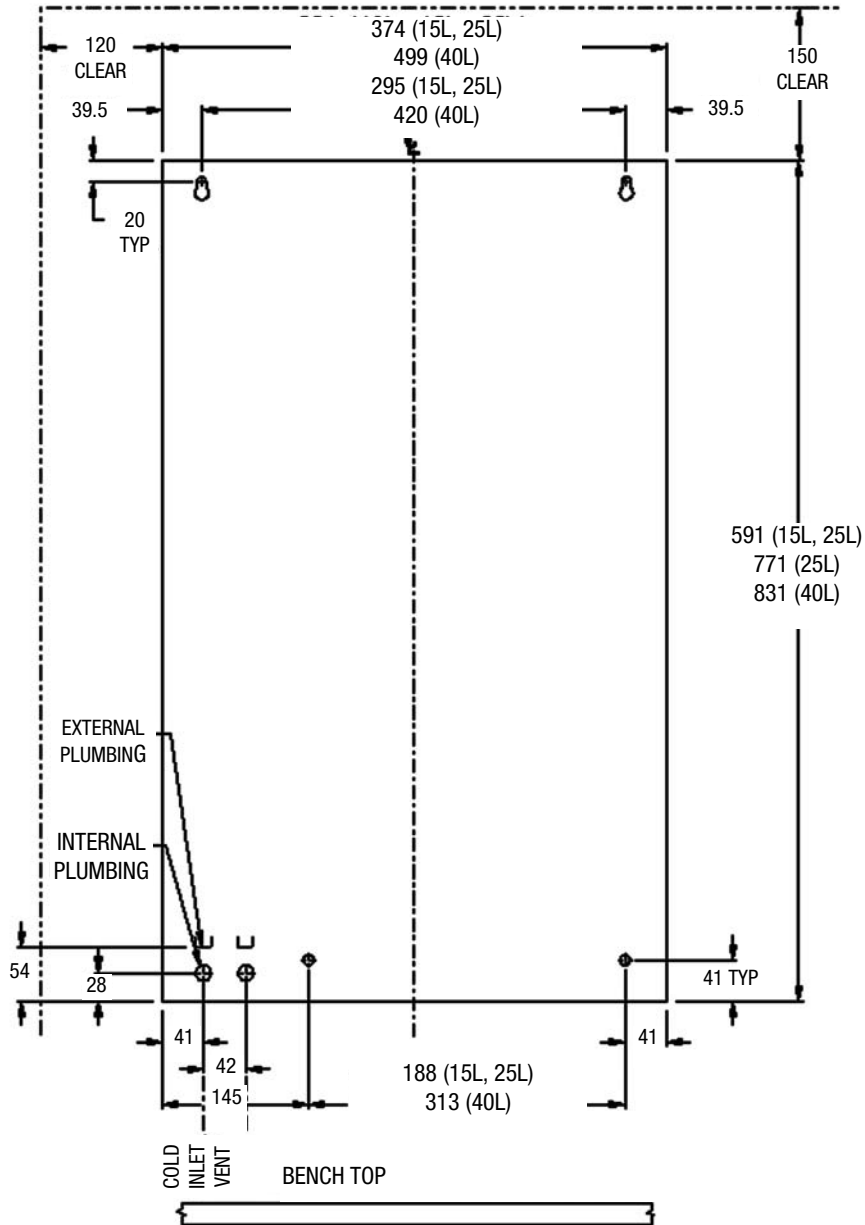

**Wall template for 15 litre, 25 litre & 40 litre models.**

## Main PCB Settings

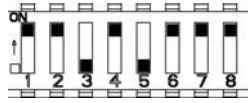

Single element factory preset.

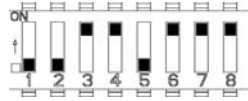

Single element altitude setting above 1000 mtrs.

### Single Element 15 Lt & 25 Lt

The single element PCB is factory pre-set to give optimum performance in all normal installation situations.

For high altitude installations (above 1000mtrs) there is an alternative dip switch setting. See both settings at left.

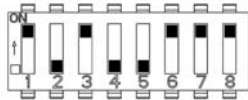

Multi element factory preset.

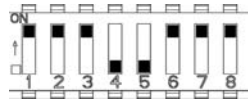

Multi element altitude setting above 1000 mtrs.

### Multi Element 40 Lt

The multi element PCB is factory pre-set to give optimum performance in all normal installation situations.

For high altitude installations (above 1000mtrs) there is an alternative dip switch setting. See both settings at left.

#### Note:

When altering the factory pre-set temperature of a multi element PCB it is important that dip switch No.4. is in the OFF position.

## Connecting John Guest Fittings

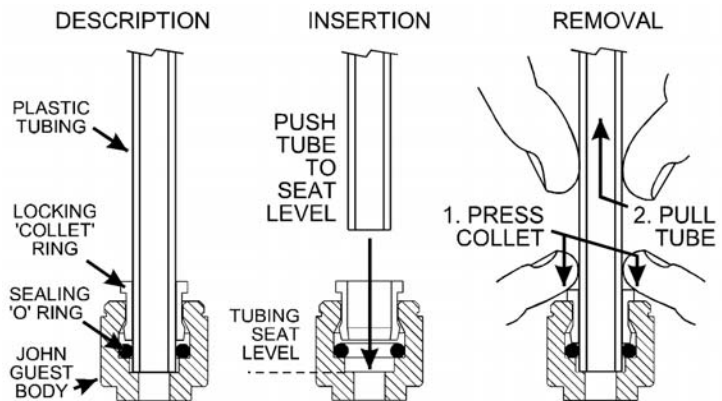

## Spare Parts

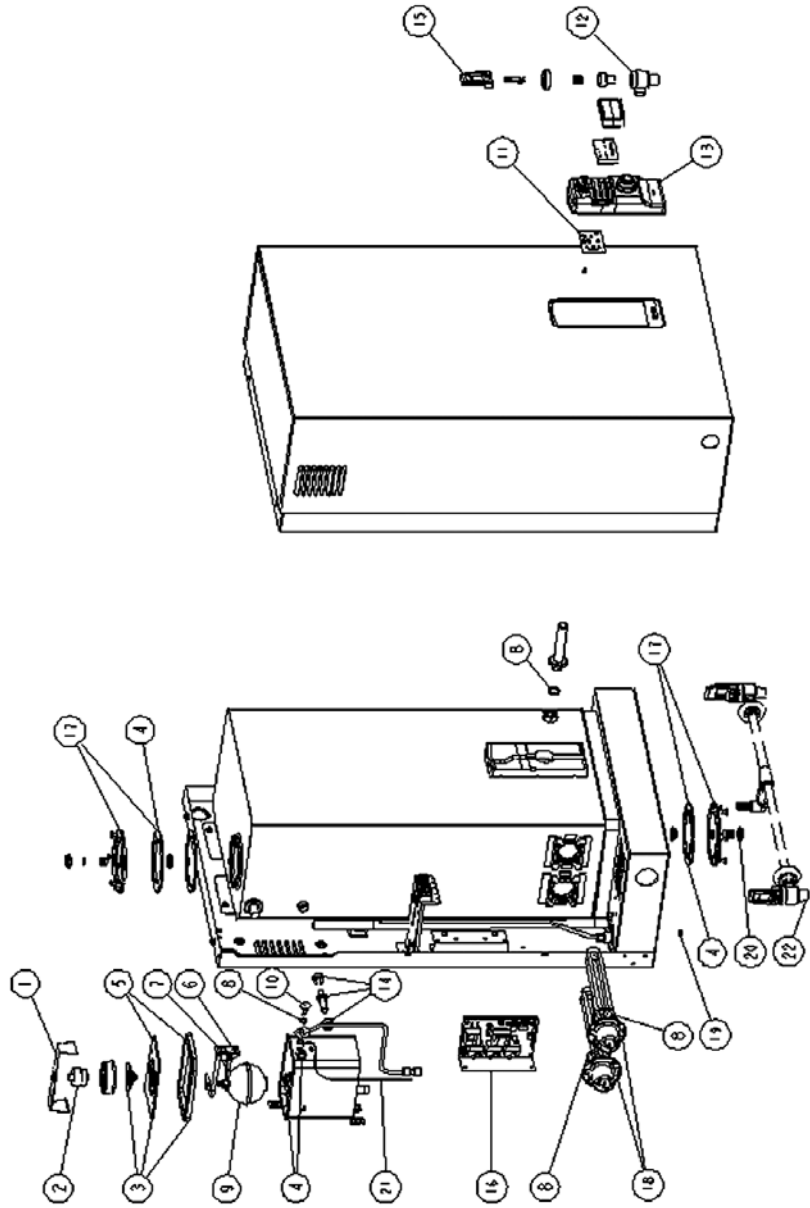

Key	Part No	Description
1	90096	Cistern Lid Clamp kit
2	90097	Overload Kit
3	90120	Disc, capsule, lid,gasket kit
4	90490	Gasket kit
5	90120	Cistern lid and gasket kit
6	90083	Float valve kit
7	90069	Jumper valve kit
8	90496	O-ring kit
9	90102	Cistern float s/nut kit
10	90495	Banjo screw kit
11	90561	PCB lights kit
12	90501	Tap top kit
13	90536	Fascia, lens and actuator kit
14	90494	Meter tube kit 2400 watt
14	90526	Meter tube kit 3000 watt x 2
14	90527	Meter tube kit 3600 watt
15	90502	Tap assembly complete
16	90594	Main PCB kit for single element
16	90596	Main PCB kit for multi element
17	90491	Clean hole cover kit
18	90123	Element kit 2400 watt 220 - 240 volt
18	90125	Element kit 2 x 3000 watt 220 - 240 volt
18	90124	Element kit 3600 watt 220 - 240 volt
18	90530	Element Kit 3000 watt 220-240 Volt
19	90107	Filter cold inlet kit
20	90492	Drain cap and seal kit
21	90587	Sensor probe kit
22	99000	Side tap kits 15 / 25 ltr
22	99001	Side tap kits 40 ltr

## Warranty Information

The Zip appliance you have chosen is precision-built from the finest materials available and should give many years of trouble free service.

Certain warranties may be implied by law into your contract with Zip. The warranty provided below is additional to these implied warranties and nothing set out below shall limit your statutory rights or rights at law.

Zip Heaters (Aust) Pty Ltd warrants that, should any part fail within 24 calendar months of installation, that part will be repaired or replaced free of charge by Zip or its Distributor or Service Provider, except as set out below, provided the appliance is installed and used strictly in accordance with the instructions supplied, and that failure is not due to accident, misuse, abuse, unsuitable water conditions, or to any alteration, modification or repair by any party not expressly nominated by Zip.

No costs are payable by the customer other than any mileage or travelling-time charges incurred by a Zip Service Provider or the cost of removal, cartage and re-installation of any component of the appliance if it needs to be returned for repair to Zip or its Distributor.

This warranty does not cover damage resulting from non-operation of the appliance or consequential damage to any other goods, furnishings or property.

No warranty applies to the life of any filtration cartridge installed with the appliance as cartridge life may vary according to water quality and the rate of water consumption.

Zip does not exclude, restrict or modify any liability that cannot be excluded, restricted or modified or which cannot, except to a limited extent, be excluded, restricted or modified as between the owner or user and Zip under the laws applicable.

Furthermore, this warranty does not displace any statutory warranty, but, to the extent to which Zip is entitled to do so, the liability of Zip under any statutory warranty will be limited at Zip's option to the replacement of the appliance or supply of equivalent appliance, the payment of the cost of replacing the appliance or acquiring an equivalent appliance, or the payment of the cost of having the appliance repaired or the repair of the appliance.

### Head Office

Zip Heaters (Aust) Pty. Ltd.  
67 Allingham Street  
Condell Park NSW 2200  
Postal: Locked Bag 80  
Bankstown 1885 Australia

Website: [www.zipheaters.com](http://www.zipheaters.com)  
Facsimile (02) 9796 3858  
Telephone (02) 9796 3100  
Free Call 1 800 638 633

### Registering Your Purchase

Registering your Zip installation on the Zip website may help to establish date of installation should it become necessary to service the appliance under terms of the Zip warranty. To register your installation go to [www.zipheaters.com](http://www.zipheaters.com) and look under the heading "Warranty".

